

LED CANOPY LUMINAIRE

DESCRIPTION

LED Canopy luminaire provides vandal-proof aluminum alloy heat sink and high shatter-proof polycarbonate diffuser. Powder-coating finished housing and sealed gasket especially are suitable for indoor or outdoor corrosion and wet/damp location. Occupancy sensor can be used for parking garage lighting, gas station, warehouse, mail and others.

CONSTRUCTION & MATERIALS

- Vandal-proof die-casting aluminum alloy housing, fully sealed to be dirt and bug proof
- Shock-proof polycarbonate diffuser with UV inhibitors
- IP 65 rating waterproof protection
- Polyester powder-coated finish, rust and corrosion proof, stabilized to extreme climate changes without cracking or peeling
- Internal UL approved Meanwell or equivalent driver

MOUNTING

- Surface Mount

ENVIRONMENTAL SYSTEM

- Indoor or Outdoor wet/damp location. IP 65 waterproof

FINISH

- Bronze

ELECTRICAL SYSTEM

- Input voltage 100-277VAC/250-480VAC, 50/60Hz
- ETL/cETL/CE/Rohs, DLC premium

OPTICAL SYSTEM

- LM 80 SMD LED
- Color temperature: 3000K, 4000K, 5000K, 5700K.
- 120 lumens per watt

LIGHTING CONTROL

- 0-10vdc/PWM dimming
- Motion sensor
- Photocell

WARRANTY

5 Years

DIMENSION

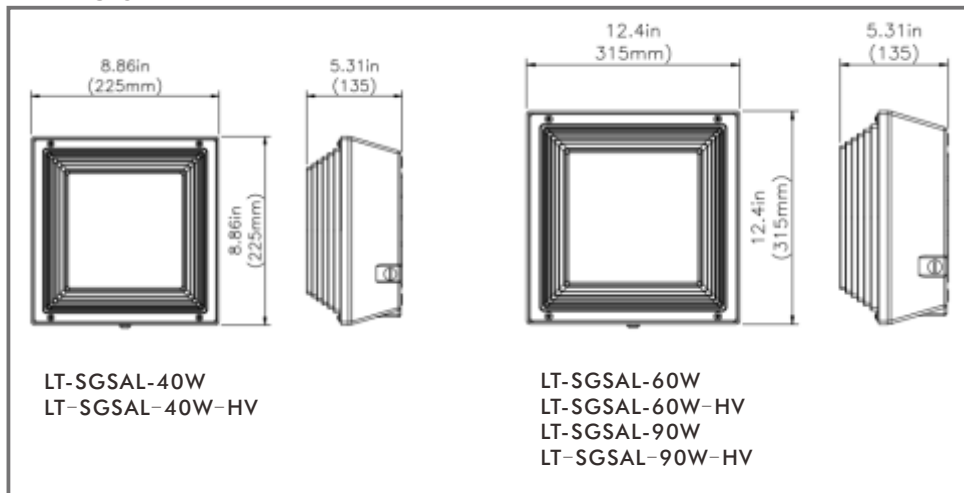

ACCESSORIES

Photocell



Motion Sensor



LED CANOPY LUMINAIRE

DATA SHEET

Model#	LT-SGSAL-40W	LT-SGSAL-60W	LT-SGSAL-90W
Rated Power	39W	58W	88W
Lumen Output @5000K	4700 lm	6800 lm	10200 lm
Input Voltage	100-277VAC, 348-480VAC		
Power Factor	0.98@100VAC 0.90 @277VAC/347-480VAC		
Color Temperature	3000K/4000K/5000K/5700K		
CRI	>70		
L70	>50,000 hrs		
Operating Temp.	-30°C~+50°C		
Store Temp.	-40°C~+60°C		
Material	Die-casting aluminum body(Bronze), PC diffuse		
Installation	Ceiling surface		
Warranty	5 Years		
Environment	Suitable for damp/wet locations, IP 65 outdoor		
Certification	ETL/cETL, DLC premium		

ORDER INFORMATION

Sample Number: LT-SGSAL-40W-HV-30K-DM

Com.	Family Name	Profile	Wattage	Voltage	CCT	Control Mode
LT Lightide	SGSA Square Gas Station Canopy	H=High L=Low	40W 60W 90W	Blank=100-277VAC HV=347-480VAC	30K=3000K 40K=4000K 50K=5000K 57K=5700K	DM=0-10VDC Dimming PC=Photocell MS= Motion sensor

PACKAGE

Model#	QTY/ Carton	N. W.	G. W.	Carton Size
LT-SGSAL-40W	8 pieces	17.90 Kg	19.90 Kg	52x52x35 cm
LT-SGSAL-60W	4 piece	15 Kg	17 Kg	70X37x37 cm
LT-SGSAL-90W	4 piece	15 Kg	17 Kg	70X37x37 cm