

Post Top LED Luminaire (Module Style)

DESCRIPTION

Lightide Post Top LED Luminaire features new led module design. Powder-coating finish especially is suitable for outdoor corrosion and wet/ damp location. DLC qualification and 5 years warranty keep better quality and long term after-sales service. The luminaire can be installed for garden, road, parking lot lighting, square and others.

CONSTRUCTION & MATERIALS

- ◆ High-duty die-casting aluminum alloy housing
- ◆ LED Module design, easy maintenance
- ◆ Shatter-proof Polycarbonate lens
- ◆ Copper or stainless steel fastener
- ◆ Polyester powder-coated finish, rust and corrosion proof, stabilized to extreme climate changes without cracking or peeling
- ◆ 2.4" or 3" diameter of base for options.

ENVIRONMENTAL SYSTEM

- ◆ IP 65 rated waterproof
- ◆ Used for outdoor wet/damp location

FINISH

- ◆ Black

ELECTRICAL SYSTEM

- ◆ Input voltage 100-277VAC, 50/60Hz
- ◆ 200-480vac available
- ◆ DLC qualified, ETL/cETL listed,
- ◆ CE/RoHS

OPTICAL SYSTEM

- ◆ 137 lm/w
- ◆ Color temperature: 3000K, 4000K, 5000K, 5700K.
Other color temperature available for special order, consult factory for lead time.
- ◆ Beam angle 140°x70° (Type II)

LIGHTING CONTROL

- ◆ 0-10vdc dimming available
- ◆ Microwave motion sensor available
- ◆ Photocell for dusk-dawn work mode available

WARRANTY

- ◆ 5 Years

STANDARD

- ◆ EN61347-1, EN61347-2-13, EN60598-2-1, EN60598-1
- ◆ UL 924, UL 1598, CAN/CSA -C.22.2 NO. 250.0,



DIMENSION

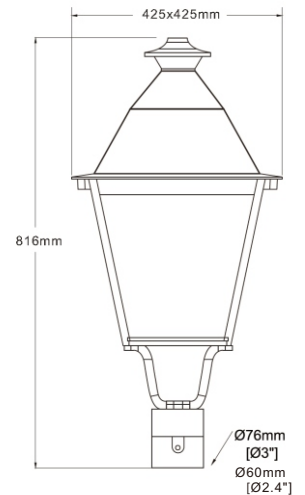

LIGHT DISTRIBUTION

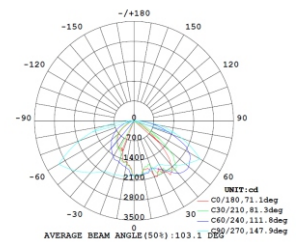

PLANAR ISOLUX DIAGRAM (UNIT:lux)

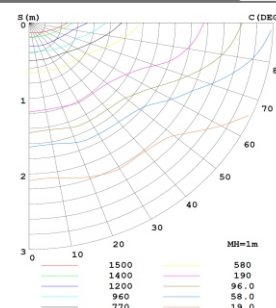

DATA SHEET

MODEL#	LT-PTB50	LT-PTB80
LED POWER	50W	80W
LUMEN OUTPUT	6818 lm	10600 lm
INPUT VOLTAGE	100-277VAC	100-277VAC
POWER FACTOR	>0.90	>0.90
COLOR TEMPERATURE	3000K~6000K	3000K~6000K
CRI	>80	>80
BEAM ANGLE	140° X70° (Type II)	140° X70° (Type II)
L70	>50,000 hrs	>50,000 hrs
OPERATING TEMP.	-20°F to 104°F	-20°F to 104°F

ORDER INFORMATION

Sample Number: LT-PTB50-HV-38K-MS

COM.	FAMILY NAME	WATTAGE	VOLTAGE	CCT	FINISH	CONTROL MODE
LT	PTB	50=50W 80=80W	Blank=100-277VAC HV=200-480VAC	30K=3000K 40K=4000K 50K=5000K 57K=5700K	Blank=Black	DM=0-10VDC Dim PC=Photocell MS= Motion sensor EM=Emergency Kit

PACKAGE

MODEL#	QTY / CTN	N. W. / CTN	G. W. / CTN	CARTON SIZE
LT-PTB50/80	1 piece	5.9 Kg	6.8 Kg	47X47X70 cm

APPLICATION

- ◆ Roadway lighting
- ◆ Parking areas lighting
- ◆ Airports lighting
- ◆ Streetscapes lighting
- ◆ Campuses lighting