

LT-SGSAL-EM

EMERGENCY BACKUP LED CANOPY LIGHTS



CONSTRUCTION & MATERIALS

- Dia-casting aluminum alloy housing, fully sealed to be dirt and bug proof
- Shock-proof polycarbonate refractor with UV inhibitors
- IP 65 & IK10 rating
- Over-current/temperature, Short/open circuit protection with auto-reset
- Built-in UL approved emergency battery backup

MOUNTING AND WIRING

- Three 3/4" mounting holes plus one on top for mounting. One installation bracket with screws are supplied in package

ENVIRONMENTAL SYSTEM

- Outdoor wet/damp location

FINISH

- Bronze

ELECTRICAL SYSTEM

- Input voltage 100-277VAC, 50/60Hz
- ETL/cETL/CE/Rohs, DLC Premium

OPTICAL SYSTEM

- 120 LPW
- Color temperature: 3000K, 4000K, 5000K, 5700K.

LIGHTING CONTROL

- 90~180min. emergency time
- Motion sensor
- Photocell

WARRANTY

5 Years

LIGHTIDE

EMERGENCY BACKUP LED CANOPY LIGHTS

Emergency backup LED garage lights provide die-casting aluminum alloy heat sink and high shock-proof polycarbonate diffuser. UL/CE approved battery back offers 90-180 min. emergency work time. DLC premium garage light offers 5 years warranty. Motion sensor and photocell sensor can be suitable for parking lot, garage, warehouse, mail, office and others.

Performance

Light Output: 120 lumens per watt
Input Power: 40/60/90 watts
Input Voltage: 100-277vac
CCT: 3000K, 4000K, 5000K, 5700K
Discharge time: 90 min. ~180 min
Charging cycles: >500 times
Charging time: 24 hrs.
EMC/FCC/IC Std.: EN55015, EN61547, EN61000-3-2/3, FCC part 15, ICES-005
Safety Std.: EN61347-1, EN61347-2-7, UI924, CSA C.22.2 NO. 141
Certificate : ETL/CETL/CE certified, DLC premium
Weight: 5.5 Kg

Refractor Option



**Low Profile
(ETL/cETL
DLC PREMIUM)**



**High Profile
(ETL/CETL)**

Dimension (Low Profile)

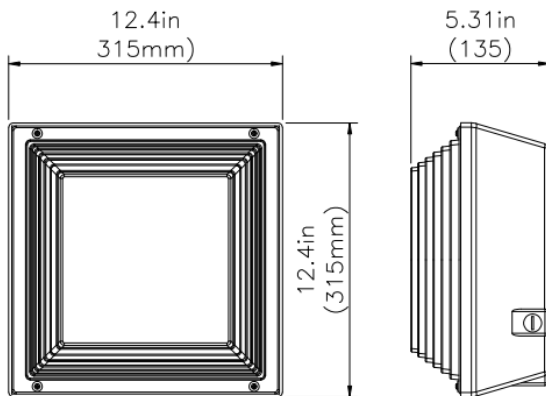

Occupancy Sensor



Motion Sensor



Photocell

Order Information

Sample Number: LT-SGSAL-40W-HV-30K-EM

Com.	Family Name	Cover Type	Watts	Voltage	CCT	Finish	Control Mode
LT Lightide	SGSA Square Gas Station Light Type A	H=High L=Low	40W 60W 90W	Blank=100-277VAC	30K=3000K 40K=4000K 50K=5000K 57K=5700K	Blank=Bronze	DM=0-10VDC Dimming PC=Photocell MS= Motion sensor EM= Emergency

MORE QUALIFIED PRODUCTS, PLEASE CONTACT

Email: info@lightide-tech.com

<https://www.lightideled.com>

Lightide Manufactory Co., Ltd All right reserved.

