

LED CANOPY LUMINAIRE-SGSB Series

DESCRIPTION

LED Canopy luminaire provides dia-casting aluminum alloy heat sink and high shock-proof polycarbonate refractor. It is suitable for indoor corrosion and wet/damp location. Motion sensor and photocell sensor can be available for parking garage lighting, gas station, warehouse, mail and others.

CONSTRUCTION & MATERIALS

- Dia-casting aluminum alloy housing, fully sealed to be dirt and bug proof
- Shock-proof polycarbonate refractor with UV inhibitors
- IP 44 rating waterproof protection
- Polyester powder-coated finish, rust and corrosion proof, stabilized to extreme climate changes without cracking or peeling
- Internal UL approved power supply

MOUNTING AND WIRING

- Mount bracket installation with screws are supplied in package

ENVIRONMENTAL SYSTEM

- Indoor wet/damp location

FINISH

- White or Black

ELECTRICAL SYSTEM

- Input voltage 100-277VAC, 50/60Hz
- ETL/cETL/CE/Rohs

OPTICAL SYSTEM

- LM 80 SMD LED
- 110-120 LPW
- Color temperature: 3000K, 4000K, 5000K, 6500K.
- Extremely wide lighting distribution

LIGHTING CONTROL

- Occupancy sensor available

WARRANTY

5 Years

ACCESSORIES & INSTALLATION

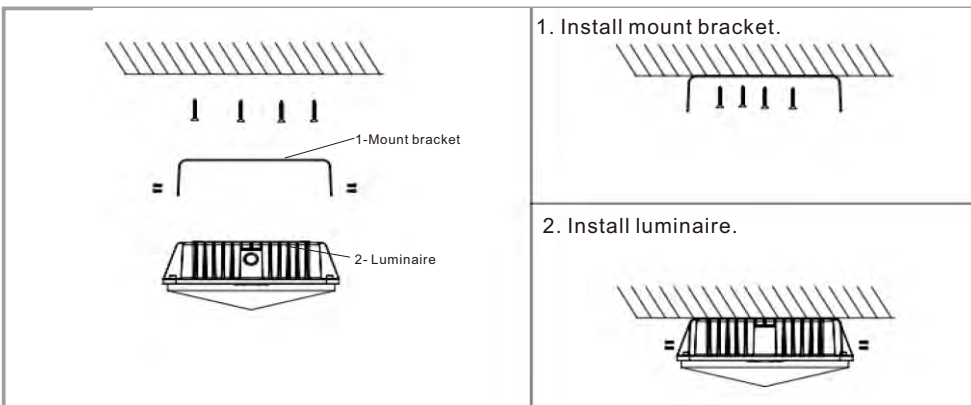

DIMENSION

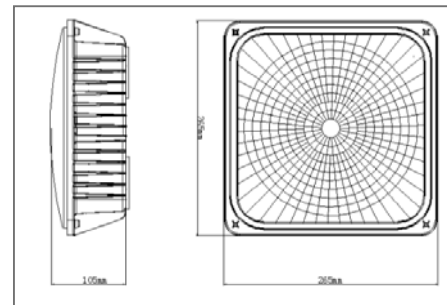

Catalog #
Type
Surface Mount
Note
Ver A 2018-06-01

LED CANOPY LUMINAIRE-SGSB Series

DATA SHEET

Model#	LT-SGSB-50W	LT-SGSB-80W
LED Power	50W	80W
Lumen Output	5800-6000 lm	8800-9600 lm
Input Voltage	100-277VAC	100-277VAC
Power Factor	>0.90	>0.90
Color Temperature	3000K/4000K/5000K/6500K	3000K/4000K/5000K/6500K
CRI	>70	>70
L70	>50,000 hrs	>50,000 hrs
Operating Temp.	-30°C~+40°C	-30°C~+40°C
Store Temp.	-40°C~+40°C	-40°C~+40°C
Material	Die-casting aluminum body, PC diffuser	Die-casting aluminum body, PC diffuser
Package	66X66X33cm/8PCS/CTN, G.W.: 21Kg/CTN	66X66X33cm/ 8PCS/CTN, G.W.: 21Kg/CTN
Warranty	5 Years	5 Years
Environment	Damp/wet locations	Damp/wet locations
Certification	ETL/cETL	ETL/cETL

ORDER INFORMATION

Sample Number: LT-SGSB-80W-30K-MS

Com.	Family Name	Wattage	Finish	CCT	Control Mode
LT	SGSB	50W	Blank=Black WH= White	30K=3000K 40K=4000K 50K=5000K 65K=6500K	DM=0-10VDC Dimming PC=PhotoCell MS= Motion sensor
Lightide	LED Canopy Light	80W			