

LT-PTB50

# POST TOP LED LUMINAIRE



## CONSTRUCTION & MATERIALS

- Dia-casting aluminum alloy housing, fully sealed to be dirt and bug proof
- Shock-proof polycarbonate refractor with UV inhibitors
- IP 65
- Over-current/temperature, Short/open circuit protection with auto-reset
- Built-in UL approved driver

## MOUNTING AND WIRING

- Pole mounted

## ENVIRONMENTAL SYSTEM

- Outdoor wet/damp location
- IP 65 waterproof

## FINISH

- Black

## ELECTRICAL SYSTEM

- Input voltage 100-277VAC, 50/60Hz
- ETL/cETL, CE/Rohs
- DLC QPL

## OPTICAL SYSTEM

- 120 LPW
- Color temperature: 3000K, 4000K, 5000K, 5700K.

## LIGHTING CONTROL

- Motion sensor
- Photocell

## WARRANTY

5 Years

# LT-PTB50

# POST TOP LED LUMINAIRE

DLC qualified Post Top LED Lights are designed with a classic profile and high output efficiency 120 lumens per watt. Powder-coating finish assures corrosion resistance and long-lasting aesthetics. 50W post top LED light fixture can replace 100W-150W metal halide lamp. The Ip65 rating and 5 years warranty are suitable for garden lighting, pathway lighting, park area lighting, parking lot lighting, and other area lightings.

### Performance

- Light Output: 120 lumens per watt
- Input Power: 50 watts
- Input Voltage: 100-277vac
- CCT: 3000K, 4000K, 5000K, 5700K
- Mount: Diameter 60mm ~76mm pole
- Safety Std.: UL1598, CAN/CSA-C.22.2 NO. 250.0, EN61347-1, EN61347-2-13, EN60598-2-1, EN60598-1
- Certificate : ETL/cETL, DLC, CE/RoHs
- Weight: 9.0 Kg

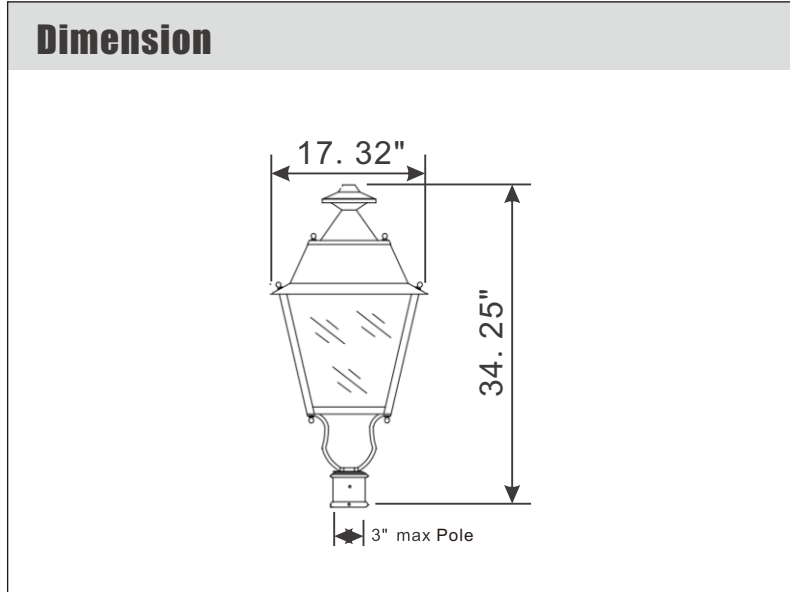

### Application

**STREET POST TOP LED LIGHTS**

### Order Information

Sample Number: LT-PTB50-30K

Com.	Family Name	Watts	Voltage	CCT	Finish	Control Mode
LT Lightide	PTB Post Top led Light B type	50=50W	Blank=100-277VAC	30K=3000K 40K=4000K 50K=5000K 57K=5700K	Blank=Black	PC=Photocell MS= Motion sensor

MORE QUALIFIED PRODUCTS, PLEASE CONTACT

Email: [info@lightideled.com](mailto:info@lightideled.com)  
<https://www.lightideled.com>  
 Lightide Manufactory Co., Ltd All right reserved.

