

LED Parking Lot Light | Street Light

Model#

LT-SBAL series

Type

3rd Gen

Note

Ver A 2020-09

DESCRIPTION

Featuring LMC's innovative LED optics, 3rd generation SBAL series LED parking lot lights are designed to deliver energy-efficient, uniform lighting in most parking lot structures with typical light pole spacing and mounting heights. It is integrated with high-performance LED chip with up to 140 lm/w. The luminaires can be installed for garden, road, parking lot lighting, square, street and others.

DATA SHEET

Model#	LT-SBAL060C	LT-SBAL100C	LT-SBAL150C	LT-SBAL200C	LT-SBAL320C
Rating	62W	100W	152W	200W	300W
Lumen Output	8450 lm	14000 lm	21280 lm	28100 lm	42630 lm
Input Voltage	100-277VAC	100-277VAC	100-277VAC	100-277VAC	100-277VAC
Power Factor	>0.90	>0.90	>0.90	>0.90	>0.90
CRI	>80	>80	>80	>80	>80
Dimension (in)	20-7/8x12-3/8x7-1/4	20-7/8x12-3/8x7-1/4	20-7/8x12-3/8x7-1/4	20-7/8x12-3/8x7-1/4	24-1/2x12-3/8x7-1/4
Weight (lbs)	12.4	12.4	13.5	17	17.6
Carton	2.29"x1.62"x0.67"	2.29"x1.62"x0.67"	2.29"x1.62"x0.67"	2.29"x1.62"x0.67"	2.96"x1.62"x0.67"
Distribution	Type III, IV, V				
LED & CCT	2700K, 3000K(*), 4000K(*), 5000K(*), 5700K, 6500K				
L70	>54,000 hrs				
Work Temp.	-20°F to 122°F				
EMC/FCC	EN 55015, EN61547, EN61000-3-2/3, FCC part 15, ICES-005				
Safety Std.	EN61347-1, EN61347-2-7, UL 924, CSA C.22.2 NO. 141.				



CONSTRUCTION & MATERIALS

- Heavy duty die-cast aluminum housing, fully sealed to be dirt and bug proof.
- New Up-Down Penetrative heat sink design to optimize thermal transfer and maximize performance and life of LED
- IP 66 rated waterproof
- Photocell mode available
- Built-in 6KV surge device
- Install directly onto the pole or surface with optional adapters.

FINISH

- Black

ENVIRONMENTAL SYSTEM

- ETL/cETL/DLC
- CE, RoHS
- Outdoor wet/damp locations

ELECTRICAL SYSTEM

- Input voltage 120-277VAC, 50/60Hz
- 250-528VAC available

OPTICAL SYSTEM

- Light distribution Type III, IV and V
- High performance 140 lm/w output

WARRANTY

5 Years

ORDER INFORMATION

Sample Number: LT-SBAL150C-HV-30K-SF-MS-T5

Com.	Family Name	Wattage	Voltage	CCT	Adapter Type	Control Mode	Distribution Type
LT	SBAL	060C=60W 100C=100W 150C=150W 200C=200W 320C=300W	Std.=100-277VAC HV=250-528VAC	30K=3000K 40K=4000K 50K=5000K 57K=5700K	SF=Slipfitter EA=Extension Arm	PC=Photocell MS=Motion sensor	T3=Type III T4=Type IV T5=Type V

DIMENSION

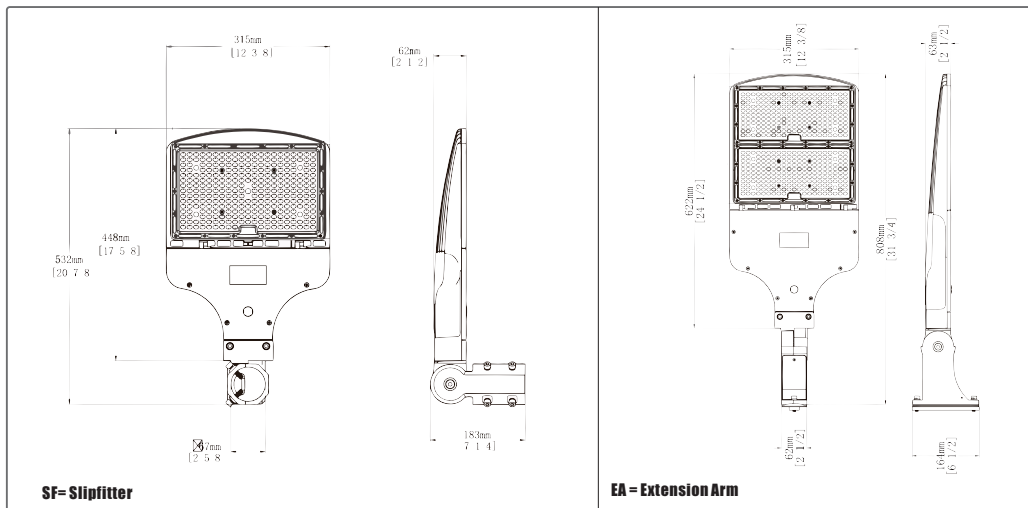

LIGHT DISTRIBUTION

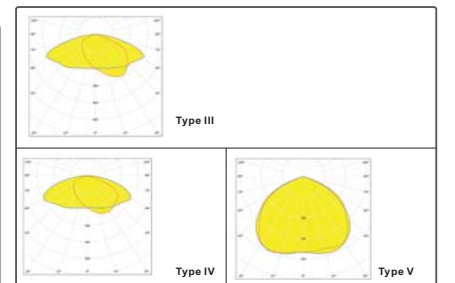

APPLICATION

- Parking Lot
- Highway
- Industrial area
- Sidewalk
- Garden
- School
- Residential area
- Commercial area