

# LED CANOPY LIGHT

DLC Premium | Vandal proof | 140 LPW

## DESCRIPTION

LED canopy lights feature smaller profile with high efficacy of 140 LPW. They also provides die-casting aluminum alloy heat sink and high shock-proof polycarbonate refractor. It is suitable for indoor corrosion and wet/damp location. Motion sensor and photocell sensor can be available for parking garage lighting, gas station, warehouse, mail and others.

### CONSTRUCTION & MATERIALS

- ◆ High-duty die-casting aluminum alloy housing, fully sealed to be dirt and bug proof
- ◆ Impact-proof glass cover
- ◆ IP 65 rating waterproof protection
- ◆ Black polyester powder-coated finish, rust and corrosion proof, stabilized to extreme climate changes without cracking or peeling
- ◆ New heat sink design to optimize thermal transfer and maximize performance and life of LED
- ◆ Driver is mounted in direct contact with the casting for a low operating temperature and long life

### MOUNTING AND WIRING

- ◆ Four mounting pieces on the top for installation.
- ◆ Conduit mount also supported

### ENVIRONMENTAL SYSTEM

- ◆ Outdoor wet/damp location
- ◆ Vandal proof location

### Finish

- ◆ Dark Bronze

### ELECTRICAL SYSTEM

- ◆ Input voltage 100-277VAC or 347VAC
- ◆ ETL/cETL, CE/RoHS.
- ◆ DLC Premium

### OPTICAL SYSTEM

- ◆ 140 lm/w output efficacy
- ◆ Color temperature: 3000K, 4000K, 5000K and 5700K. Other color temperature available for special order, consult factory for lead time.
- ◆ 140 degree beam angle

### LIGHTING CONTROL

- ◆ 0-10vdc dimming available
- ◆ Microwave motion sensor available

### WARRANTY

- ◆ 5 Years

### STANDARD

- ◆ EN61347-1, EN61347-2-13, EN60598-2-1, EN60598-1
- ◆ UL 924, UL 1598, CAN/CSA -C.22.2 NO. 250.0,

Model # LT-SGSAH series

Type Surface Mount

Note Ver A1 2021-02



## DIMENSION

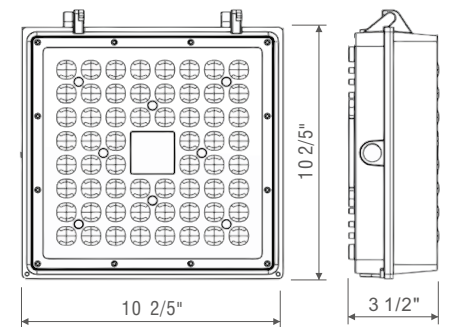

## DATA SHEET

MODEL#	LT-SGSAH-60W	LT-SGSAH-90W	LT-SGSAH-120W
DLC FAMILY CODE	WWWBPF	WWWBPE	PENDING
LED POWER	60W	100W	120W
LUMEN OUTPUT	7800 lm	14400 lm	17400 lm
INPUT VOLTAGE	100-277VAC	100-277VAC	100-277VAC
POWER FACTOR	>0.90	>0.90	>0.90
L70	>50,000 hrs	>50,000 hrs	>50,000 hrs
OPERATING TEMP.	-30°C~+40°C	-30°C~+40°C	-30°C~+40°C
DIMENSION (L*W*H)	10 2/5" X 10 2/5" X 3 1/2"	10 2/5" X 10 2/5" X 3 1/2"	10 2/5" X 10 2/5" X 3 1/2"

## ORDER INFORMATION

Sample Number: : LT-SGSAH-60W-HV-50K-PC-WH

COM.	FAMILY NAME	WATTAGE	VOLTAGE	CCT	ACCESORIES	FINISH
LT	SGSAH	60W 90W 120W	Std.=100-277vac HV= 200-480VAC	30K=3000K 40K=4000K 50K=5000K 57K=5700K 65K=6500K	DM=0-10VDC Dimming PC=Photocell MS= Motion sensor	Blank=Bronze WH=White

## INSTALLATION

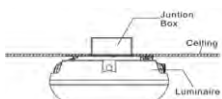

### SURFACE MOUNT

## ACCESSORIES

MS-Motion Sensor Microwave



Mount Kits

## LUMINAIRE PHOTOMETRIC

