



TPA Series

Vapor-Tight LED Light



TPA

LED Garage Light Highbay Fixture



LED garage lights are surface mount or suspended overhead ceiling lights ideal for task and general ambient lighting. These led garage lighting is commonly used for mechanic shops, workstations, home garages and storage rooms.

Vapor-tight linear LED Garage Lights 4ft feature power selectable ranges of 32-40-50 watts and CCT selectable ranges of 3000K-4000K-5000K. And they also are built with a 1-10vdc dimming and motion sensor. Therefore, these linear garage led lights are powerful lighting in harsh environments, protecting the light source from dust and moisture.

Catalog#	Type
Comment	
Project	Date

DESCRIPTION

LED Garage Lights can be adjustable power ranged from 32watts, 40 watts to 50 watts and CCT changed from 3000K, 4000K and 5000K. And they also are built with a standard 1-10vdc dimming driver. In addition, the fixtures feature vapor-tight rated housing, which also are IK08 and V0 rated and coming with frosty or clear strip cover for option. Waterproof Ip66 rated fixtures are suitable for indoor or outdoor wet/damp usage. High lumen output level up to 150 LPW of led vapor tight light fixtures usually are applied for storage areas, warehouses, shops and garages etc.

CONSTRUCTION & MATERIALS

- ◆ IK 08 & V0 shatter-proof polycarbonate housing
- ◆ Lm80 SMD 2835 LED with Ra>80
- ◆ Shatter-proof & Frosty cover
- ◆ Liquid tight connector available
- ◆ Stainless steel fastener

INSTALLATION

- ◆ Chain Pendant/Surface mounted

ENVIRONMENTAL SYSTEM

- ◆ IP 66 rated for wet and damp location usage
- ◆ Indoor/outdoor wet/damp location
- ◆ Ambient Temp.: -30°C - +50°C (-22°F -122°F)

FINISH

- ◆ Grey

ELECTRICAL SYSTEM

- ◆ Input voltage 100-277VAC, 50/60Hz
- ◆ ETL/cETL listed,
- ◆ CE/RoHS
- ◆ DLC QPL

OPTICAL SYSTEM

- ◆ 130 LPW /150 LPW.
- ◆ CCT selected range from 3000K-4000K-5000K
- ◆ Beam angle 120°

LIGHTING CONTROL

- ◆ 0-10vdc dimming available
- ◆ Power selected from 32W-40W-50W
- ◆ Microwave motion sensor available
- ◆ Photocell for dusk-dawn work mode available

WARRANTY

- ◆ 5 Years

STANDARD

- ◆ EN61347-1, EN61347-2-13, EN60598-2-1, EN60598-1
- ◆ UL 924, UL 1598, CAN/CSA -C.22.2 NO. 250.0,

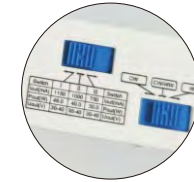

POWER & CCT
SELECTABLE

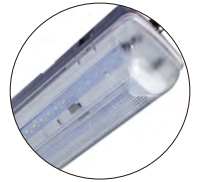

CLEAR COVER
OPTION



DATASHEET

Model#	LT-TPA220	LT-TPA436	LT-TPA440CP	LT-TPA444CPT	LT-TPA810
Input Voltage	100-277vac	100-277vac	100-277vac	120-347vac	100-277vac
Rated Power	20W	40W	Selectable 32W-40W-50W	Selectable 32W-44W-50W	100W
Output Efficacy	130/150 LPW	130/150 LPW	130/150 LPW	130/150 LPW	130/150 LPW
CRI	>80	>80	>80	>80	>80
Beam Angle	120°	120°	120°	120°	120°
CCT	3000K/4000K/5000K	3000K/4000K/5000K	3000K/4000K/5000K	Selectable 3000K-4000K-5000K	3000K/4000K/5000K
L70 Life	>50,000hrs	>50,000hrs	>50,000hrs	>50,000	>50,000hrs
Optional Battery	Lithium/Ni-MH	Lithium/Ni-MH	Lithium/Ni-MH	Lithium	Lithium/Ni-MH
Duration (minutes)	90 (120/180 Options)	90 (120/180 Options)	90 (120/180 Options)	90 (120/180 Options)	90 (120/180 Options)
Housing	UL94-V0 Rated	UL94-V0 Rated	UL94-V0 Rated	UL94-V0 Rated	UL94-V0 Rated
Cover	PC (frosty, clear)	PC (frosty, clear)	PC (frosty, clear)	PC (frosty, clear)	PC (frosty, clear)
Certificate	ETL/cETL, CE/RoHS,DLC	ETL/cETL, CE/RoHS,DLC	ETL/cETL, CE/RoHS	ETL/cETL, CE/RoHS, DLC	ETL/cETL, CE/RoHS

ORDER INFORMATION

Sample Number: LT-TPA444CPT-MS-EM-2H-C

Com	Series	Length	Wattage	CCT	Control Mode	Duration (EM)	Cover
LT	TPA	2=2FT 4=4FT 8=8FT	20 =20W 36 =40W 40CP= Tunable 32W-40W-50W 44CP= Tunable 32W-44W-50W 10 =100W	30K=3000K 40K=4000K 50K=5000K T=3000K-4000K-5000K Selectable	MS=Motion Sensor EM=Emergency Backup	Std.= 90 minutes 2H= 120 minutes 3H= 180 minutes	Blank= Frosty C=Clear

Catalog#	Type
Comment	
Project	Date

DIMENSION

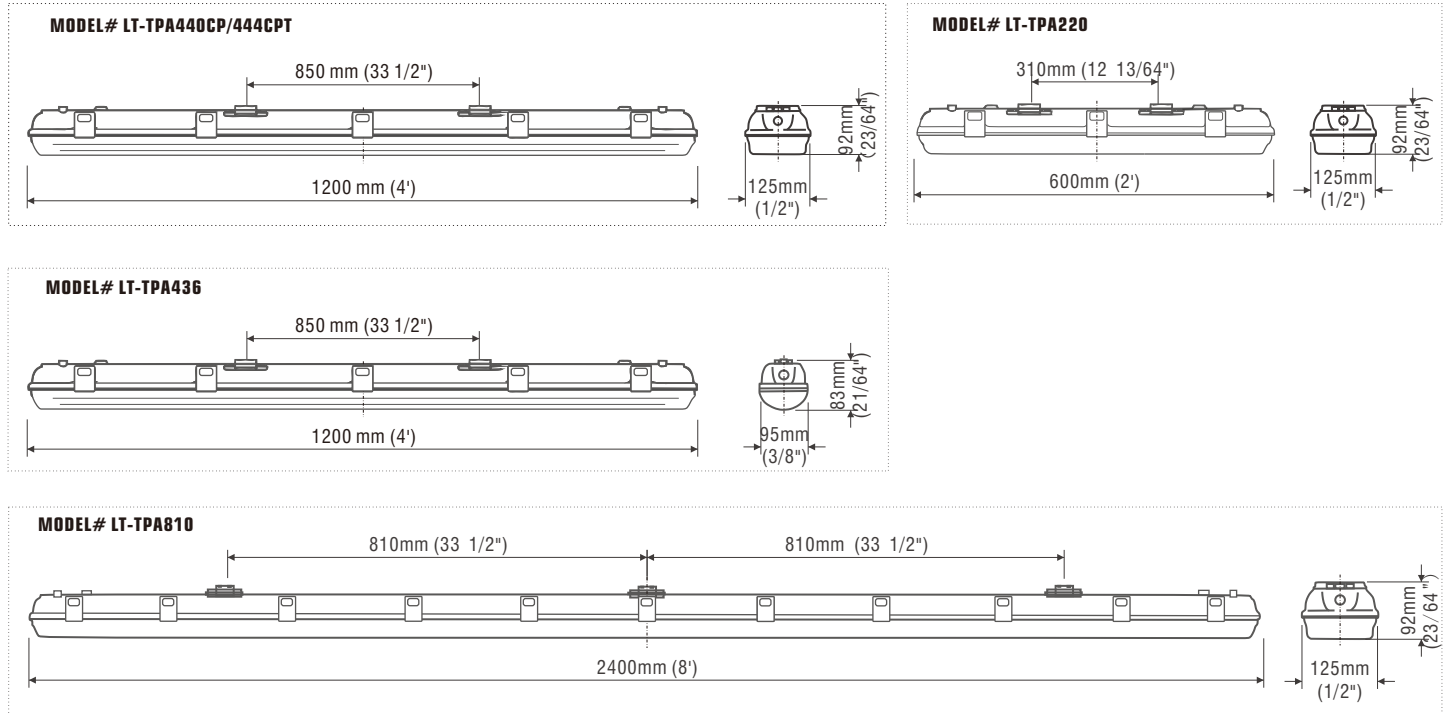

PHOTOMETRICS (FROSTY COVER)

MODEL# LT-TPA440CP 49W 4,000K 6,298 Lumens

MODEL# LT-TPA436 40W 4,000K 5,169 Lumens

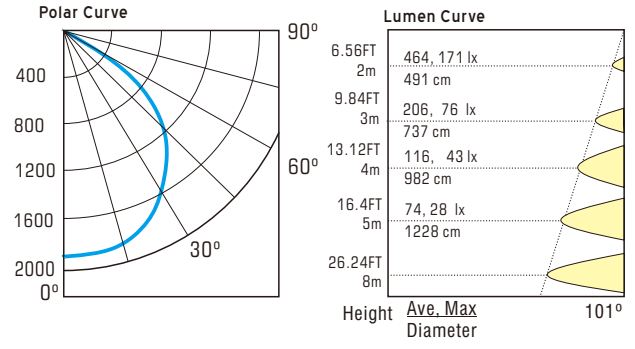
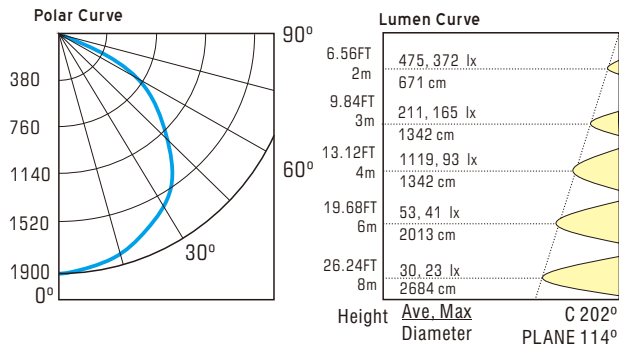

PHOTOMETRICS (CLEAR COVER)

MODEL# LT-TPA440CP 48.8W 4,000K 7,167 Lumens

MODEL# LT-TPA436 41W 4000K 5,879 Lumens

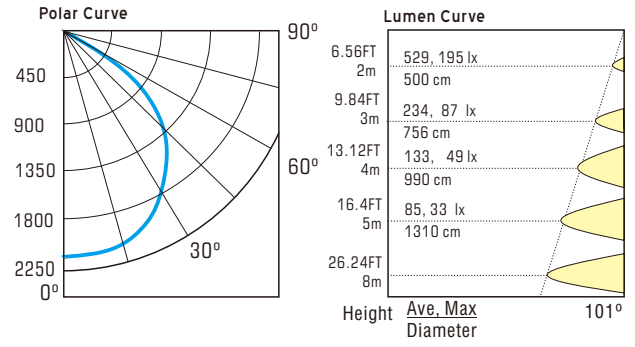
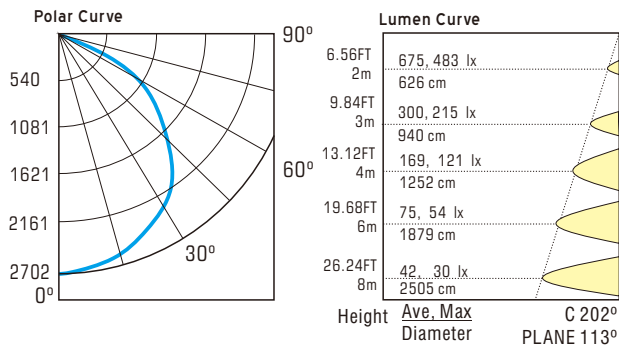

Catalog#	Type
Comment	
Project	Date

PACKAGE				
NO.	Model#	Carton Size (LXWXH)	G. W. / CTN	QTY/CTN
1	LT-TPA220	68X31X34	9 Kg	6
2	LT-TPA436	128X35X33cm	19.5 Kg	9
3	LT-TPA440CP/444CPT	128X31X34cm	16.8 Kg	6
4	LT-TPA810	248X31X25	24 Kg	4

WIRE DIAGRAM

Wire Diagram

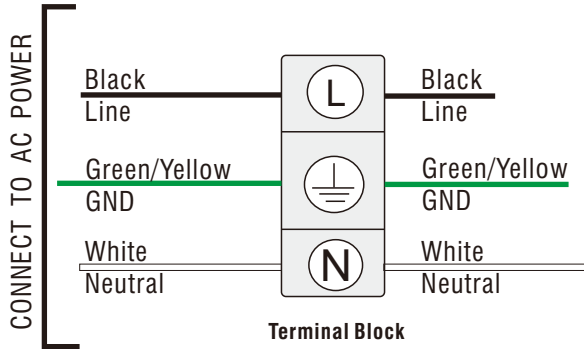

Emergency Wire Diagram (Switch)

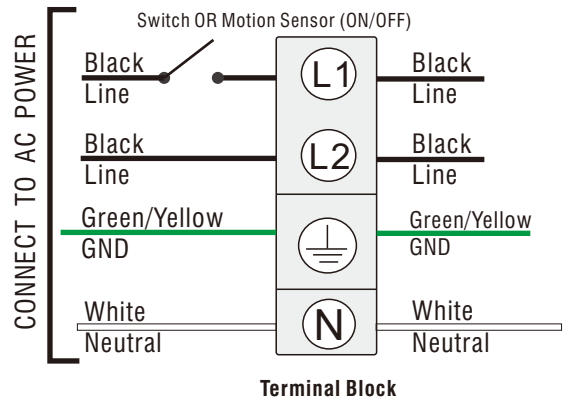

ACCESSORIES & MOUNT GUIDE

This LED garage light is easily installed to the ceiling with suspending kit. No hard-wiring is needed. A lot of time and labor costs will be saved.



Standard Package Kit



Optional Suspended Kit (5ft long)



Optional Conduit Fitting Liquid Tight Connector

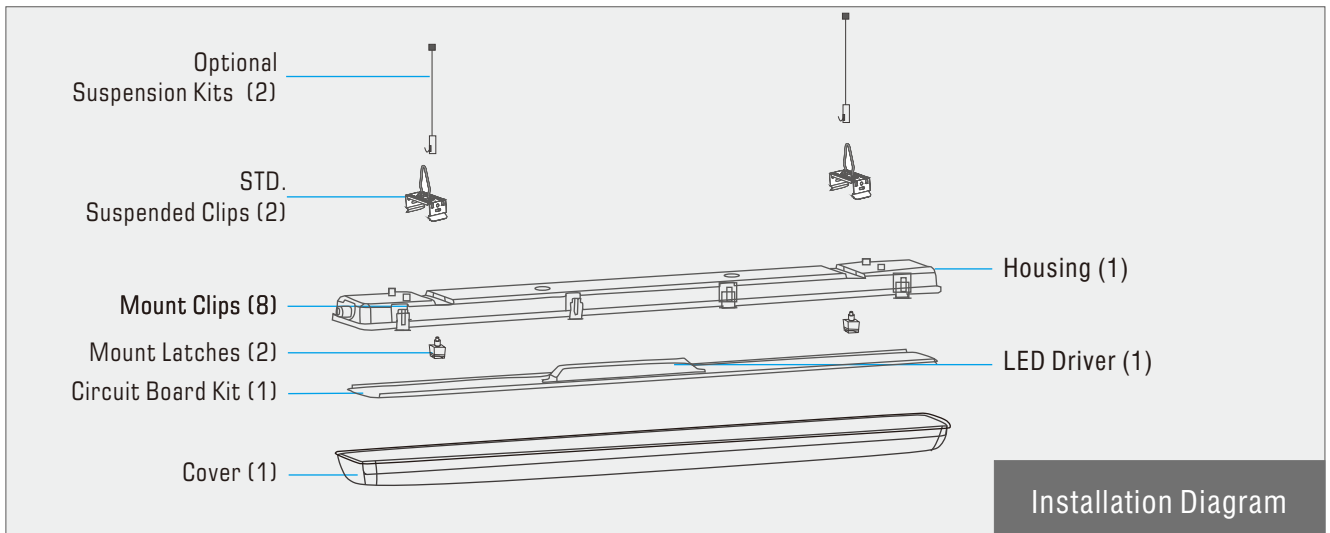

Installation Diagram

Catalog#	Type
Comment	
Project	Date

OPTIONAL MOTION SENSOR

Motion Sensor is a moving object sensor that can detect range of 360° and its working frequency is 5.8GHz. The advantage is stable working state (stable working temperature: -40°C ~ +70°C), adopts a microwave sensor (high-frequency output < 0.2mW), so that it is safe and performs better than infrared sensor.

Features

- Fully adjustable high and low dimmed light levels from 0-10VDC
- Designed for LED fixtures; rated for extreme temperatures and up to 200,000 on/off cycles
- Adjustable via handheld wireless configuration tool
- Adjustable time delay and cut off delay from 10 seconds to 60 minutes
- Provides line voltage On/Off switching and 0-1 0VDC dimming control
- Works with ballasts or LED drivers
- Adjustable ramp up and fade down times
- High inrush stability zero crossing circuitry for reliable, long-life operation catching relay is durable for all load

Daylight Harvest Function

This function inside the motion sensor to achieve tri-level control, for some areas which require a light change notice before switch-off. The sensor offers 3 levels of light: 100% --> dimmed light (natural light is insufficient) --> off; And 2 periods of selectable waiting time: motion hold-time and stand-by period; Selectable daylight threshold and freedom of detection area.



ON-OFF MODE

The microwave sensor to achieve tri-level dimming control, for same areas that require a light change notice before switch off.



With sufficient ambient light, the sensor does not switch on the lamp.



With insufficient ambient light, the sensor switches on the lamp when motion is detected.



After hold time, the lamp gradually dims down if no motion detected.

3-STEP DIMMING MODE

It offers 3 levels of the light Control: 100%-dimming light (0,10%,30%,50%) --off; and 2 periods of selectable waiting time: motion hold-time and stand-by time. Selectable daylight threshold and choice of detection area.



With sufficient ambient light, the sensor does not switch on the lamp.

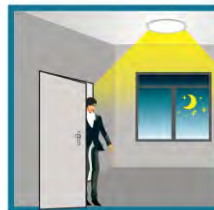

With insufficient ambient light, the sensor switches on the lamp when motion is detected.

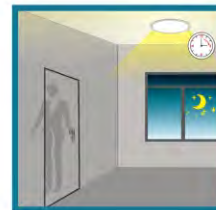

After hold time, the sensor dims the lamp at a low light level if no new motion trigger.



After stand-by period, the sensor switches off the lamp if no motion is detected in its detection zone.

OPTIONAL EM BATTERY

When the AC power goes out, the emergency driver detects the AC power outage and automatically switch to the working emergency mode. The green LED light off. When the AC power is restored, the emergency driver backs to AC power working and starts re-charging, the green LED light on.

Features

- Meet most of safety standards for lighting
- Battery protections over charge protection over discharge protection short circuit protection
- Standard CSA C22.2 NO.141, UL924
- External Li-ion, LiFePO4 or Ni-MH battery
- The batteries Meet 500 cycles of standard CH and standard DCH
- Indicator shows a variety working modes
- RoHS compliant
- Standard 1.5 hours (2 hrs, 3hrs for options)

Specifications

- Input Voltage: 100-277Vac, 50/60Hz
- AC Input Current: 100mA max.
- AC Input Power Rating: 7.0W max.
- Output Current and Voltage: 25-48Vdc
- Output Power: 8W /15W
- Emergency Time: ≥1.5H
- Full Warranty: 5 Years
- Test Switch Indicator Light
- Illuminated Test Switch, indicator Light

